

This drawing is property of NV RENSON, and may not be copied or shown to thirds without written permission.

1 | 2 | 3 | 4 | 5 | 6 | 7 | 8

A | B | C | D | E | F

A | B | C | D | E | F

Zijaanzicht
Vue de côté
Side view
Seitenansicht
Vista lateral

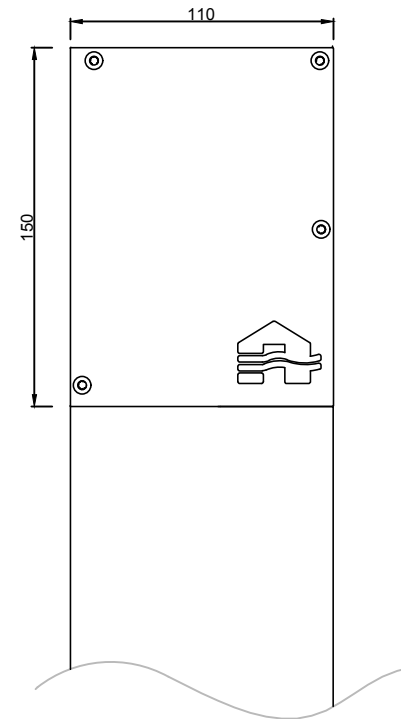

Doorsnede
Section
Cross section
Section
Sección

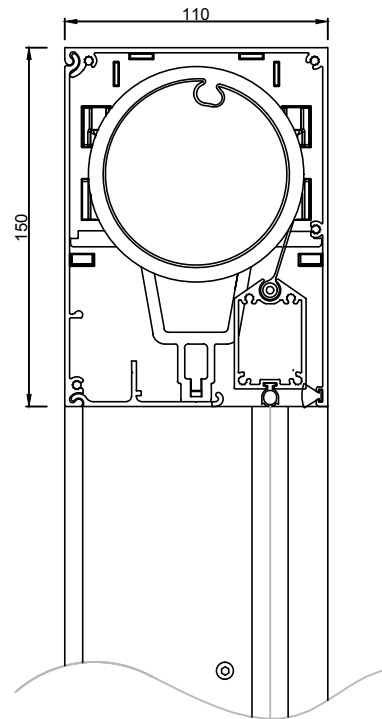

Bovenaanzicht
Vue de dessus
Top view
Obenansicht
Vista desde arriba

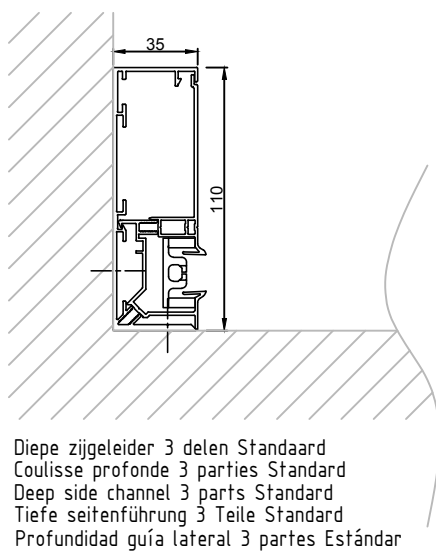

3D aanzicht
Vue en 3D
3D-View
3D-Ansicht
Vista 3D

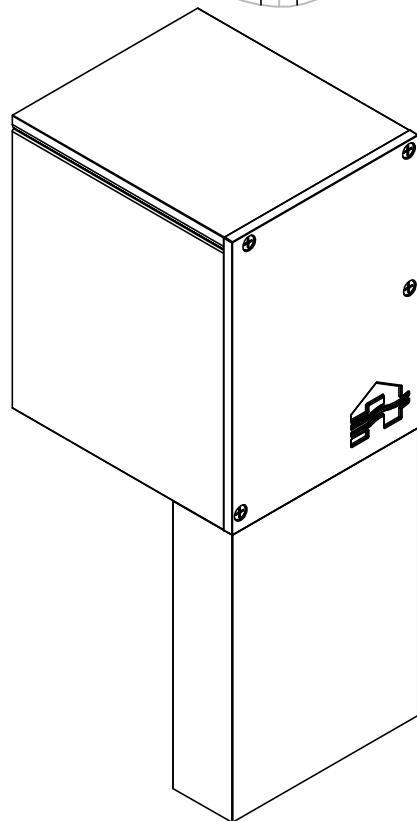

Diepe zijgeleider 3 delen Standaard
Coulisse profonde 3 parties Standard
Deep side channel 3 parts Standard
Tiefe seitenführung 3 Teile Standard
Profundidad guía lateral 3 partes Estándar

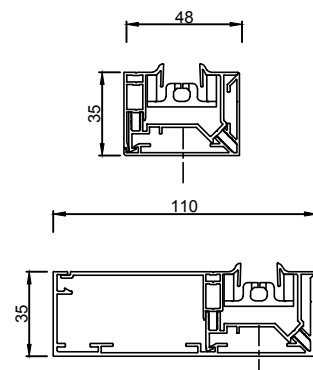

Zijgeleider 3 delen
Coulisse 3 parties
Side channel 3 parts
Seitenführung 3 Teile
Guía lateral 3 partes

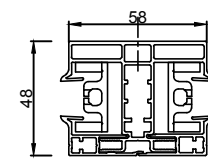

Koppel zijgeleider (K)
Coulisse d'accouplement (K)
Coupling side channel (K)
Koppel- Führung (K)
Guía lateral de acoplamiento (K)

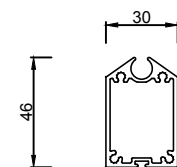

Onderlat
Barre de charge
Bottom rail
Die Endschiene
Perfil contrapeso



Industriezone "Flanders field"
8790 Waregem (Belgium)
Tel. 056/62.71.11 Fax. 056/60.28.51

Drawn by
msple

Date
2/10/2017

Scale
1/3

Fixscreen® 100^{EVO} SLIM

Version
1

A3

MS7A / M7A / IM7A / EW7A / TdM7A

Page
1/1



1 | 2 | 3 | 4 | 5 | 6 | 7 | 8